



CONTENTS

WOOD 5 - 9

STONE 11 - 15

PRODUCT
INFORMATION 17 - 19

AMTICO CLICK STYLE THAT SIMPLY FITS

QUICK AND EASY TO INSTALL, AMTICO CLICK FEATURES AN INSPIRING RANGE OF AUTHENTIC WOOD AND STONE DESIGNS.

YOU CAN INSTALL AMTICO CLICK EASILY OVER UNDERLAY - IT DOESN'T REQUIRE ADHESIVE AND ONCE FITTED IS QUIET UNDERFOOT AND LOOKS BEAUTIFUL.

Front cover image: Linear Sandstone
Left hand image: Saddle Oak



WOOD

OUR WOODS RANGE IS DESIGNED TO SUIT A WIDE RANGE OF INTERIORS, FROM CHARMING, RUSTIC, CHARACTER FILLED HOMES, TO SLEEK AND BOLD, MODERN SPACES.





TREATED OAK

Pale, beautifully distressed lime wash surface, created to bring calm and airy seaside lightness to your space.



LINDEN OAK

Soft, sandy tones with a delicate feathery grain, this is a surface to bring natural warmth and comfort to the home.



SUMMER OAK

Fill your rooms with gold, sunny light with this warm and honey-toned grained finish, for a traditional or modern look.



COLUMBIAN WALNUT

Deliciously deep cocoa tones with a fine grain for a classic style to blend or contrast with your living space.

STONE

EFFORTLESSLY STYLISH, THIS RANGE GIVES A NATURAL FEEL AND IS PERFECT FOR COOL, CALM AND CRISP CONTEMPORARY SPACES.



CERAMIC FROST

Ceramic Frost's delicate details and fresh, light colourings make this cool stone a perfect choice for your space.



LINEAR SANDSTONE

The soft grain running through this stone product gives a look that's subtle but completely modern. Warm cream tones and sandy striations make this an ideal option for your home.



SLATE JET

This dark cool black slate mixes paler greys in movement and detail. A timeless choice that can add a dynamic edge to contemporary spaces or sit classically in a traditional interior.

WOOD



Linden Oak

SC5W3010



Treated Oak

SC5W3011



Summer Oak

SC5W3012



Saddle Oak

SC5W3013



Chapel Oak

SC5W3014



Columbian Walnut

SC5W3015

Amtico Click Woods are available in 178 x 1245mm (7" x 49").
Visit amtico.com for detailed size availability.

STONE



Ceramic Frost

SC5S6100



Crema Travertine

SC5S6101



Linear Sandstone

SC5S6102



Sift Stone Neutral

SC5S6103

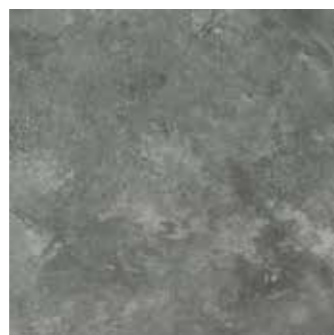

Slate Flint

SC5S6104



Slate Jet

SC5S6105

Amtico Click Stones are available in 305 x 610 mm (12" x 24").
Visit amtico.com for detailed size availability.

INSTALLATION

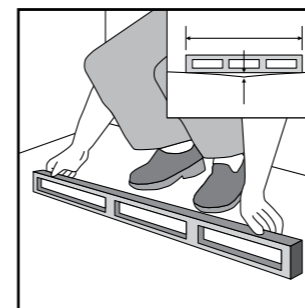

Step 1

The base should be smooth and flat

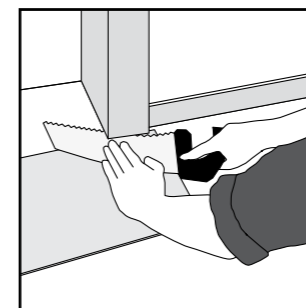

Step 2 (optional)

Undercutting of door frames

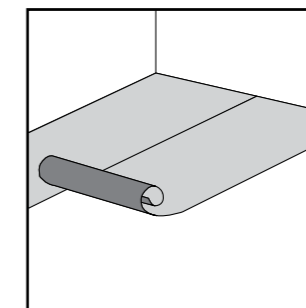

Step 3

Laying of Amtico International Underlay-19. Outside of roll should be placed facing down.

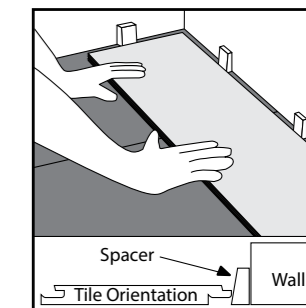

Step 4

Laying of first plank with tongue side facing wall using spacers

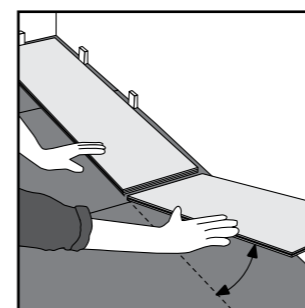

Step 5

Fitting of second tile

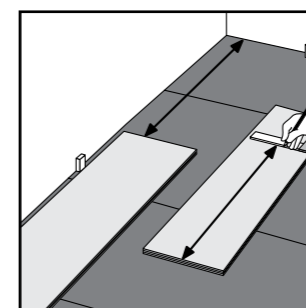

Step 6

Cutting and fitting of final plank in first row

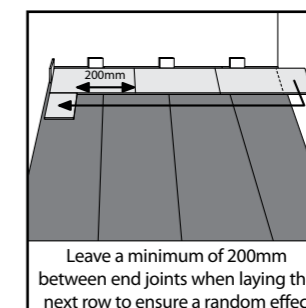

Leave a minimum of 200mm between end joints when laying the next row to ensure a random effect

Step 7 (optional)

Use of offcut from previous row

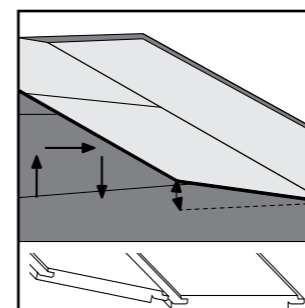

Step 8

Fitting of additional planks in second row

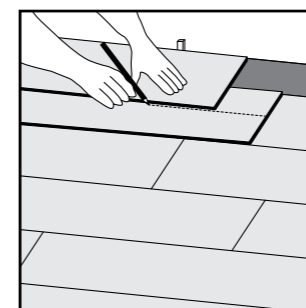

Step 9

Measure and cut final row of planks allowing for expansion gap

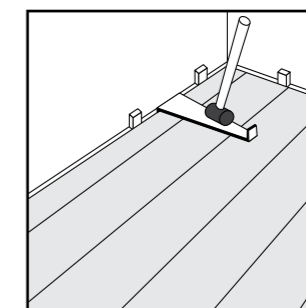

Step 10

Pullbar and rubber mallet can be used for final row of planks, ensuring an expansion gap

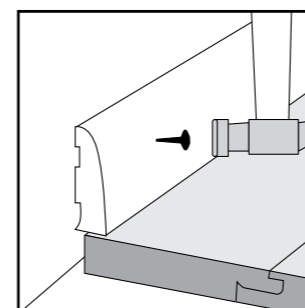

Step 11

Refitting of skirting board with hidden expansion gap

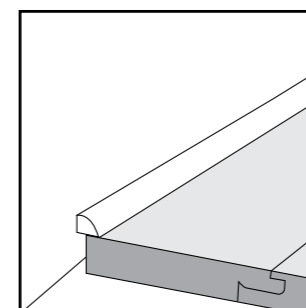

Step 12

Fixing edge trim to wall

WEAR & CARE

CARE

- Avoid using aerosol sprays and other silicone based products as overspray can leave a residue and make the floor slippery.
- Use Amtico International Entrance Matting at all external doorways. This will help reduce the chance of water, excess grit, dirt, small stones and other debris being walked onto the floor. Some rubber backed matting can cause permanent staining.
- Spillages should be wiped up immediately. Residues of oils and greases are potential slip hazards, the affected area should be thoroughly cleaned with Amtico International FloorCare Maintainer, or our ready to use Amtico International Spillage Remover.
- Avoid contact with rubber, asphalt, some paints and shoe polishes, which can potentially stain your floor.
- Do not allow cigarettes, matches or other hot items to be deposited on the floor as permanent damage is likely to occur.
- Amtico International floors have good scratch resistance properties, however sharp edges on some items of furniture can damage the floor and care should be taken when using vacuum cleaners as they may scratch your floor.
- The use of furniture cups, felt pads or glides are essential to help reduce the risk of scratching your floor.
- Do not drag heavy items of furniture across the floor as this can result in serious scratch marks. Care should be taken with a brand new floor, when furniture and other appliances are being fitted or placed back into the space.
- Castors, furniture cups and other means of load spreading will help reduce the risk of indentation to the floor when used under heavy load bearing furniture and appliances.
- Do not use Steam Mops as these may cause damage to the tile.

ROUTINE CLEANING

Amtico International FloorCare Maintainer
Our concentrated cleaner, with a fresh, citrus aroma for routine cleaning.

Amtico International FloorCare Spillage Remover
A ready to use cleaner with a citrus aroma. Formulated for the convenient removal of spills and other deposits.

Amtico International FloorCare Stripper
This should be used periodically to remove the existing dressing and provide a clean floor, ready for an application of Amtico International FloorCare Dressing.

Amtico International FloorCare Dressing
A specially formulated polish with a satin finish which will help provide added protection against scuffing and scratching.

We do not advocate the use of other cleaning products, as they may not work as efficiently or effectively and may cause damage to the floor or leave the surface with a slippery residue.

NEXT STEPS

FIND A RETAILER



Visit one of our Flooring Specialists for expert guidance on choosing your Amtico Click floor.
To find your nearest retailer visit us at amtico.com or call us on 08703 50 40 90

ORDER SAMPLES

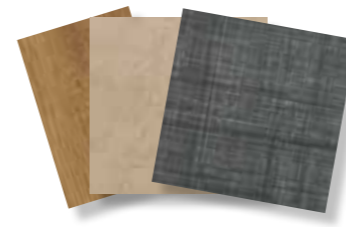

Search for Amtico Click products on our website and order samples of your favourite products.
Select up to 6 samples free of charge, visit amtico.com, email us at samples@amtico.com or call us on 08703 50 40 90

WARRANTY



You can be assured of our commitment to quality and durability.
All Amtico Click products come with a 20 year transferable warranty against wear out.

VISIT AMTICO.COM

Visit our website to find inspiration for your home. Browse our gallery of images, search for wood, stone and abstract designs and view full product information.

CONTACT US

Amtico International
UK & European Sales
Solar Park Southside
Solihull, West Midlands
B90 4SH
+44 (0) 8703 50 40 90
samples@amtico.com

Every effort is made to achieve accurate reproduction of products in this brochure, however printing limitations can be misleading. Selection of products should be made from actual samples. Samples are small pieces cut from standard tiles. They give only a general indication of the design. Tone and shading can vary slightly from batch to batch, and it is not possible to guarantee that the sample will exactly match the material supplied. The policy of the Company is one of continuous development and improvement and the right is reserved to add or delete from the range or change patterns without prior notification.

amtico.com
samples@amtico.com
70-LI-267 (UK Q3 2013)

